

When booting FPGA from RPI, MISO and MOSI switch. Send bitstream out MISO0. This requires bitbanging the SPI stream. Keep SPI_CS low when driving CRESET high.

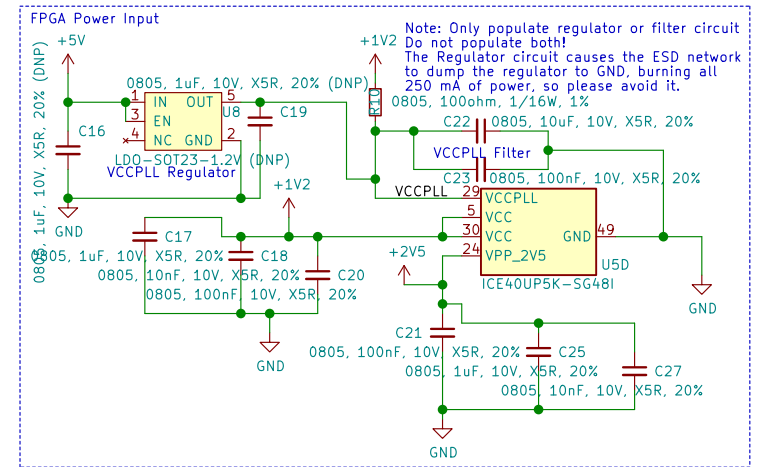
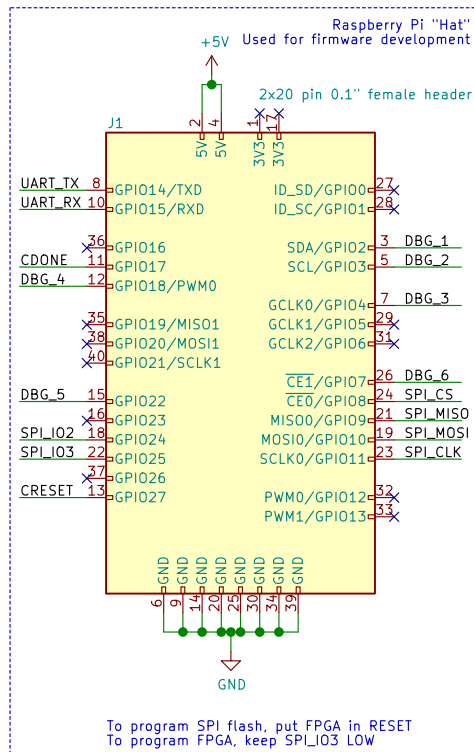
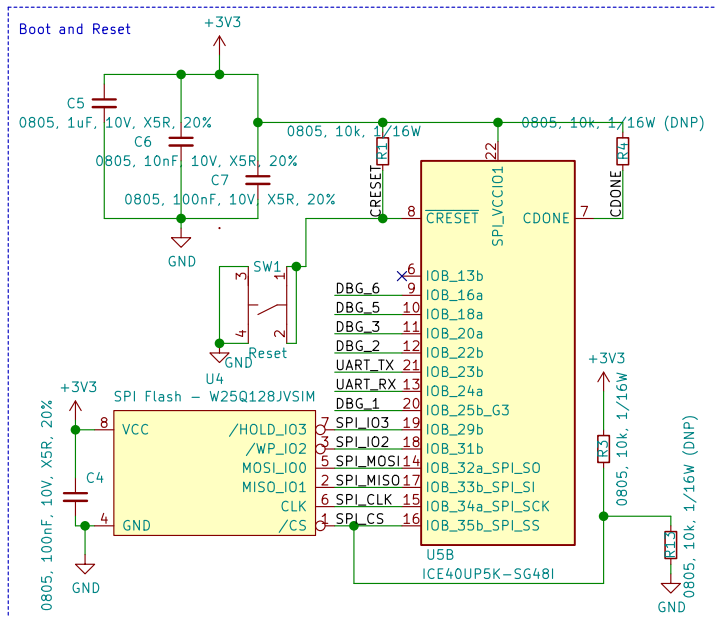
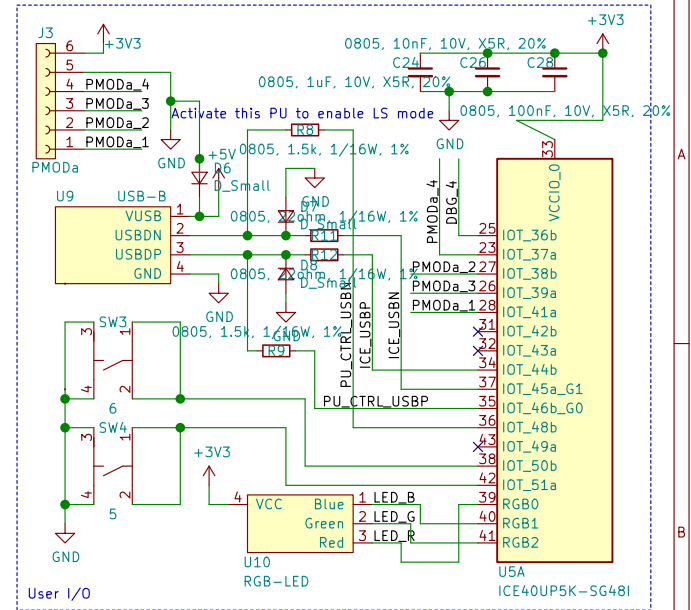

Stretch PCB for electrical verification

Foosn PTE Ltd.

Sheet: /
 File: tomu-fpga.sch

Title: Fomu

Size: A4 Date: 2018-12-29
 KiCad E.D.A. kicad (5.0.1)-3

Rev: EVT3b
 Id: 1/1